

Distributed Exclusively By  
**Keystone Automotive Operations, Inc.**  
44 Tunkhannock Avenue, Exeter, PA 18643  
**1.866.638.4870**  
WarrantyServices@key-stone.com  
www.FX-Product.com



***Premium Series***  
***Single Row Straight LED Light Bar***



Premium Series  
Single Row Straight LED  
Light Bar



Part No: 2SRS20CC01, 2SRS30CC01, 2SRS40CC01,  
2SRS50CC01



30-60 min

Cutting Not  
Required

Drilling  
Required



REMOVE CONTENTS FROM BOX. VERIFY ALL PARTS ARE  
PRESENT.



READ INSTRUCTIONS CAREFULLY BEFORE STARTING  
INSTALLATION.



DO NOT OVER TORQUE. STANDARD OPERATING LOAD FOR HTEN  
BODY MOUNT NUTS & BOLTS VARIES FROM 45 TO 65 FOOT



support@trailfx.com



1 866 638 4870



LIMITED TWO YEARS



LIGHT BAR



WIRING HARNESS



SWITCH



MOUNTING KIT



BLACK PVC COVER

Part # 2SRS20CC01 Parts List

Qty	Part Description	Qty	Part Description
1	Light Bar	3	M6 Spring Washer
1	Wiring Harness	3	M6 Lock Nut
1	Switch	6	M4*4 Lock Screw
3	Sliding Block	3	M8*25 mm Bolt
3	Rubber Pads	3	M8 Flat Washer
3	Bottom Bracket	3	M8 Spring Washer
3	M6*40 mm Bolt	3	M8 Lock Nut
3	M6 Flat Washer	1	M2 Spanner

Part # 2SRS30CC01 Parts List

Qty	Part Description	Qty	Part Description
1	Light Bar	4	M8 Spring Washer
1	Wiring Harness	4	M8 Lock Nut
1	Switch	1	M2 Spanner
4	M6 Spring Washer	4	Sliding Block
4	M6 Lock Nut	4	Rubber Pads
8	M4*4 Lock Screw	4	Bottom Bracket
4	M8*25 mm Bolt	4	M6*40 mm Bolt
4	M8 Flat Washer	4	M6 Flat Washer

Part # 2SRS40CC01 Parts List

Qty	Part Description	Qty	Part Description
1	Light Bar	5	M8*25 mm Bolt
1	Wiring Harness	5	M8 Flat Washer
1	Switch	5	M8 Spring Washer
5	M6*40 mm Bolt	5	M8 Lock Nut
5	M6 Flat Washer	1	M2 Spanner
5	M6 Spring Washer	5	Sliding Block
5	M6 Lock Nut	5	Rubber Pads
10	M4*4 Lock Screw	5	Bottom Bracket

Part # 2SRS50CC01 Parts List

Qty	Part Description	Qty	Part Description
1	Light Bar	6	M8*25 mm Bolt
1	Wiring Harness	6	M8 Flat Washer
1	Switch	6	M8 Spring Washer
6	M6*40 mm Bolt	6	M8 Lock Nut
6	M6 Flat Washer	1	M2 Spanner
6	M6 Spring Washer	6	Sliding Block
6	M6 Lock Nut	6	Rubber Pads
12	M4*4 Lock Screw	6	Bottom Bracket



BOTTOM BRACKET MOUNTING KIT

## SIDE BRACKET INSTALLATION:



## LIGHT INSTALLATION:

1. Identify the desired mounting location for the lights on the vehicle. Place light bar and mark bracket hole locations on vehicle (If mounting hole requires drilling).
2. If mounting hole requires drilling, drill a diameter of 0.39"(10mm) hole in locations marked.

## BOTTOM BRACKET INSTALLATION

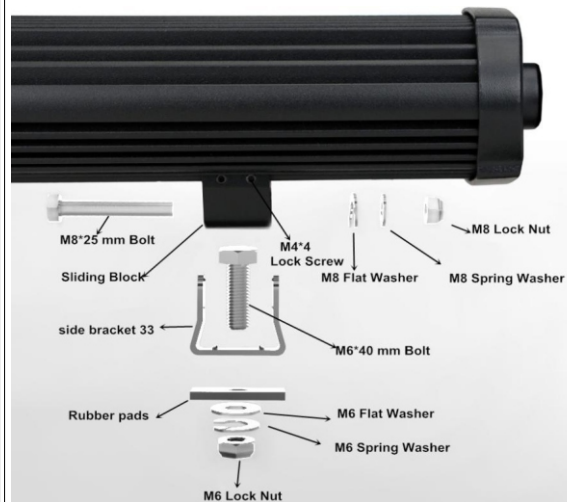

## WIRING INSTALLATION:

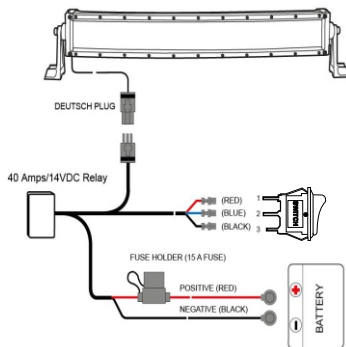

1. Remove wiring harness and switch from kit.
2. Route wiring harness so that the red and black power cables are routed to the 12V battery, the three switch wires are routed to your desired switch location, and the Deutsch plug(s) is routed to the light. (Keep wiring away from anything that will get hot).
3. Mount relay with desired hardware in a position under hood or in cab that is limited to water exposure.
4. Plug male (on the wiring harness) and female (on light) Deutsch plug(s) connectors together.
5. Drill a hole in desired switch mounting location. Verify there will be enough clearance behind switch to plug in the wires. Notch a small slit in the side of the hole using a file. This will keep the switch from turning.
6. Press switch into hole; verify that the notch made in step 5 lines up with the notch on the switch.
7. Plug wires into switch. Prongs on switch will be marked 1 through 3. Red wire goes to prong 1, Blue wire goes to Prong 2, and the Black wire goes to prong 3 (gold prong).
8. Attach power cable to the battery. Red goes to positive and black goes to negative.

- Do periodic inspections to the installation to make sure that all hardware is secure and tight.
- Never use a caustic or petroleum based cleaner on any surface of the light.
- For best cleaning results, always use household glass cleaner or mild soap with a soft lint free rag.

Check out these other TrailFX Products!!

www.FX-Products.com



Keystone Automotive Operations Inc. (KAO) warrants this product to be free of defects in material and workmanship at the time of purchase by the original retail consumer. KAO disclaims any other warranties, express or implied, including the warranty of fitness for a particular purpose or an intended use. If the product is found to be defective, KAO may replace or repair the product at our option, when the product is returned prepaid, with proof of purchase. Alteration to, improper installation, or misuse of this product voids the warranty. KAO's liability is limited to repair or replacement of products found to be defective, and specifically excludes liability for any incidental or consequential loss or damage.